

CODE OPTIONS

CSD-1* Manual Reset LWCO
 *Argus control is factory programmed for one ignition trial.

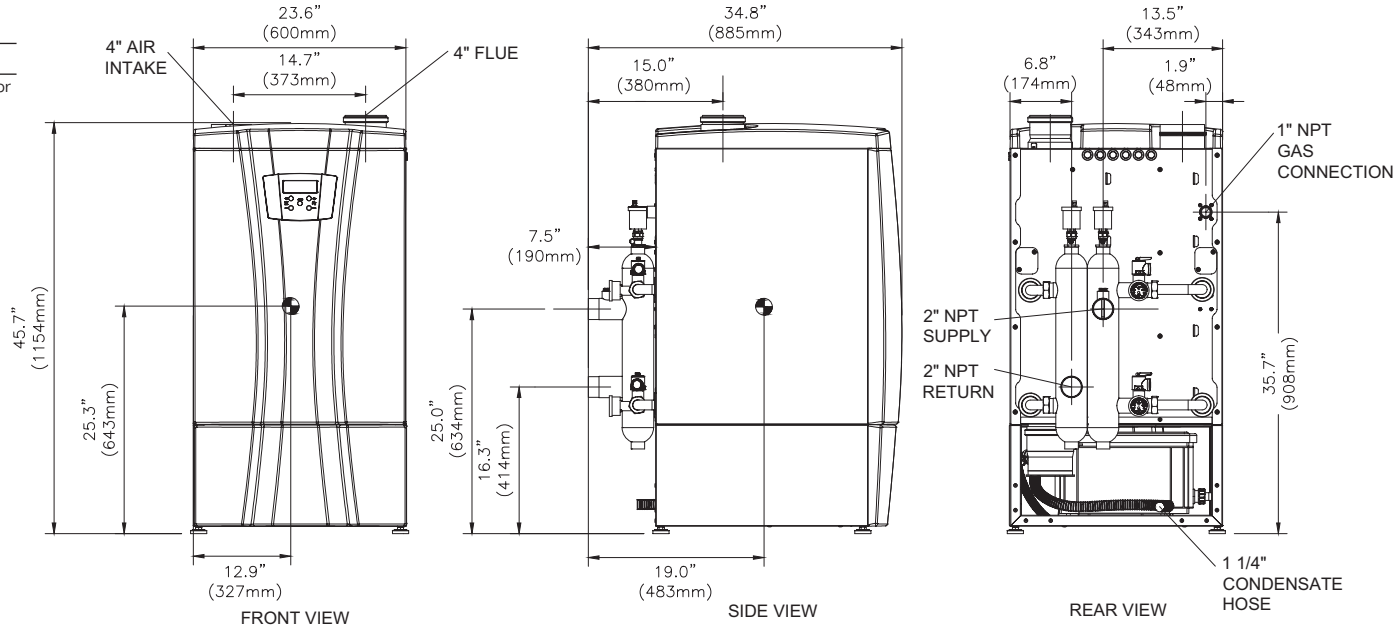

- Notes:**
 1. Dimensions are approximate and should not be used to "rough-in" equipment.
 2. Dimensions are subject to change without notice.
 3. Ⓞ Symbol indicates center of gravity.

BOILER CERTIFIED RATINGS & CAPACITIES

Fuel Type	Natural/Propane Gas	Boiler FLA	1.83*
Input BTU/hr.	399,000 / 117 kW	Min. Gas Pressure Required	3" W.C.**
Output BTU/hr.	375,858 / 110 kW	Max. Gas Pressure Allowed	13" W.C.
Electrical Requirements	120VAC/ 1 ph/ 60 hz	Operating Weight	340 lbs. / 154 kg.

BOILER TEMPERATURE RISE / PRESSURE DROP

25°F / 13.9°C				30°F / 16.7°C				35°F / 19.4°C			
Flow Rate		Pressure Drop		Flow Rate		Pressure Drop		Flow Rate		Pressure Drop	
GPM	L/s	Ft	kPa	GPM	L/s	Ft	kPa	GPM	L/s	Ft	kPa
30.1	1.9	18.0	53.8	25.1	1.6	12.5	37.4	21.5	1.4	8.5	25.4

BOILER / WATER HEATER TRIM & CONTROLS

Main Gas Valve	Sit 848 Sigma	Air Switch	HUBA
Ignition Control	Argus	Blower Motor	EBM
Operating Control	Argus	Relief Valve - IW	3/4" x 3/4" @ 125 psi
High Limit	J2D-AOVJ	Relief Valve - IB	3/4" x 3/4" @ 50 psi

WATER HEATER HOURLY RECOVERY CAPACITY (GPH & LPH)

40°F	22°C	60°F	33°C	80°F	44°C	100°F	56°C	120°F	67°C	140°F	78°C
1154	4364	770	2909	577	2182	462	1745	385	1455	330	1247

A.S.M.E.

ASME Sect IV Htg Surface	9.60 Sq. Ft. / .90 Sq. M.	Design Data	Max. 160 psig & 210°F
Water Volume	3.4 gal / 12.87 Liters		

* Add circulator amps.
 ** For incoming gas pressures lower than 3" W.C. natural or propane, consult factory.

REP FIRM	_____	<p>INFINITE ENERGY 2-399</p> <p>Category II or IV Appliance</p> <p>(see Installation and Operation Manual for venting information)</p> <p>RBI® A Division of Mestek, Inc. Westfield, MA 01085 (413) 564-5515</p> <p>RELIABLE. BOLD. INNOVATIVE.</p>
SUBMITTED BY	_____	
JOB NAME	_____	
ARCHITECT	_____	
ENGINEER	_____	
CONTRACTOR	_____	
DATE	_____	